

TAG	X LOC	Y LOC	SIZE
A1	-4.6250	-1.8231	#7 (0.201) DIAMETER HOLE ϕ .2010 THRU ALL
A2	-2.6250	-1.8231	#7 (0.201) DIAMETER HOLE ϕ .2010 THRU ALL

TITLE: DWG. NO. cs1000-mnt-FAB		
SIZE A	MATERIAL FINISH	REV
SCALE: 1:1	WEIGHT:	SHEET 1 OF 4

5



4

3

2

1

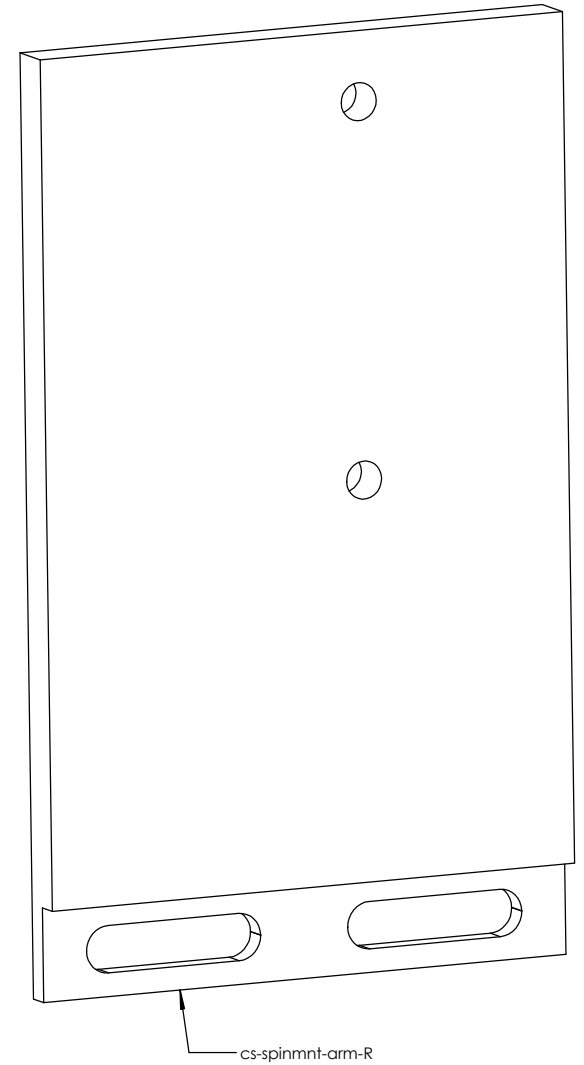
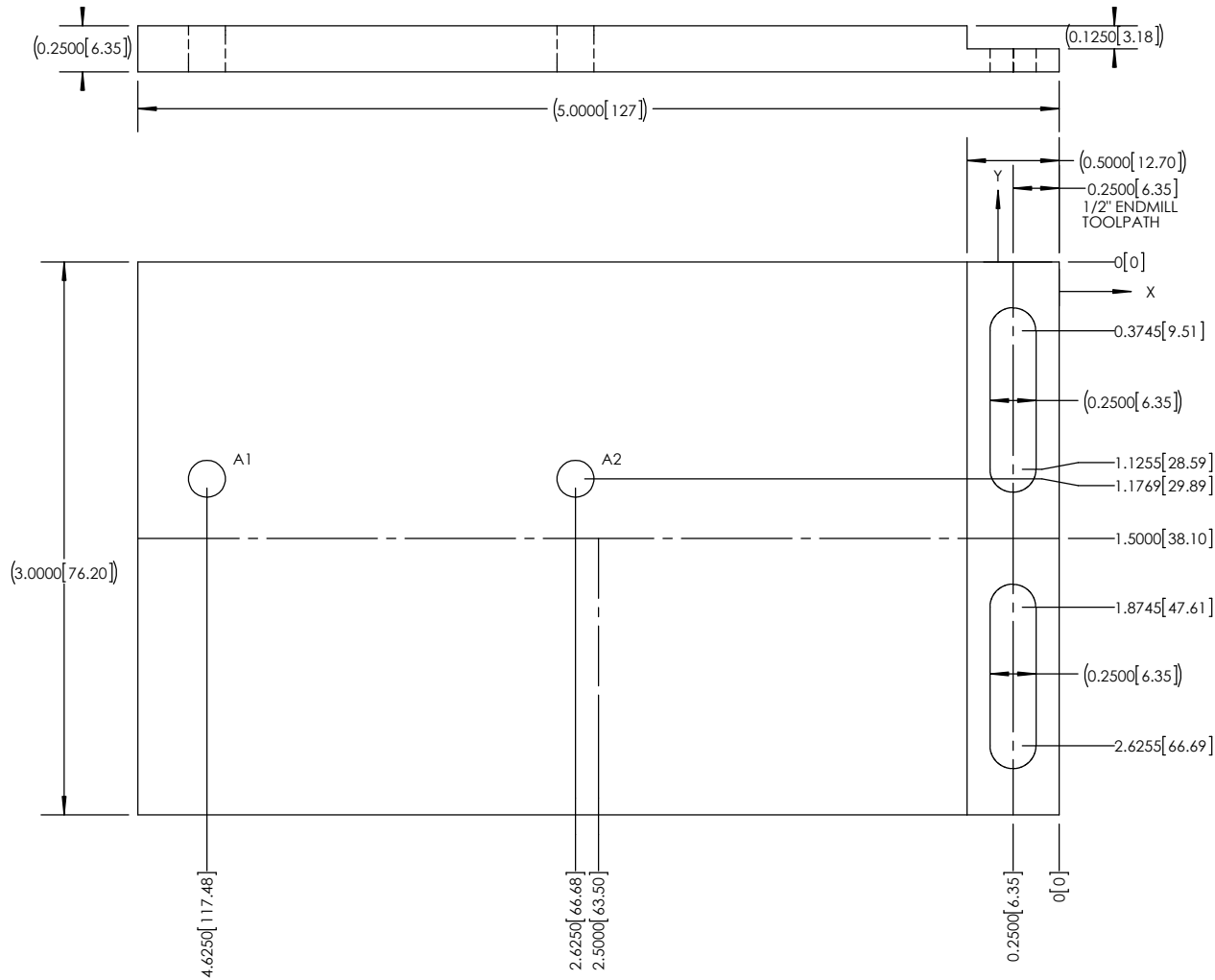

TAG	X LOC	Y LOC	SIZE
A1	-4.6250	-1.1769	#7 (0.201) DIAMETER HOLE ϕ .2010 THRU ALL
A2	-2.6250	-1.1769	#7 (0.201) DIAMETER HOLE ϕ .2010 THRU ALL

SIZE	DWG. NO.	REV
A	cs1000-mnt-FAB	
SCALE: 1:1	WEIGHT:	SHEET 2 OF 4

5

4

3

2

1

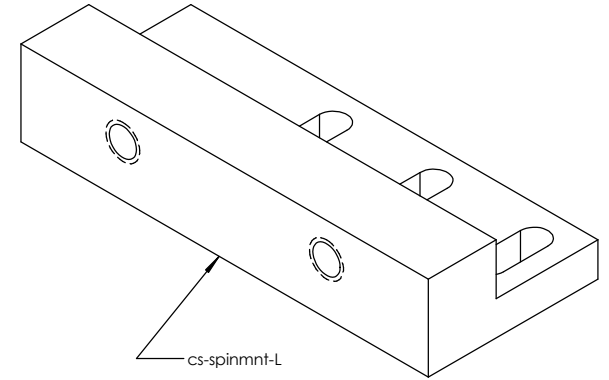
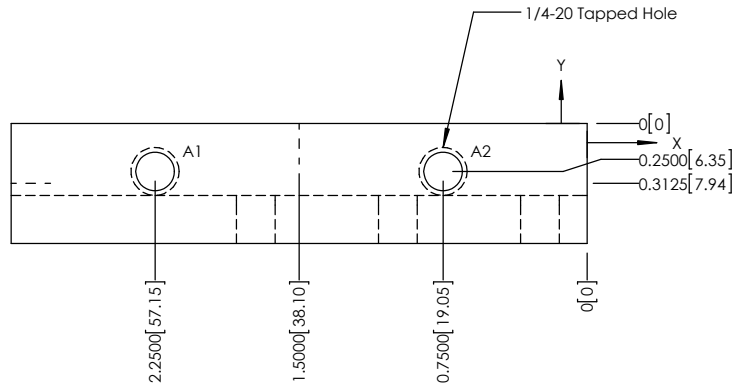
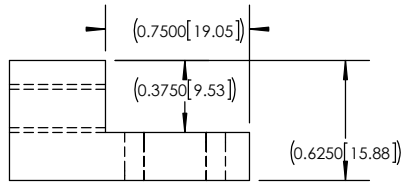

TAG	X LOC	Y LOC	SIZE
A1	-2.2500	-0.2500	Ø .2010 THRU ALL 1/4-20 UNC THRU ALL
A2	-0.7500	-0.2500	Ø .2010 THRU ALL 1/4-20 UNC THRU ALL

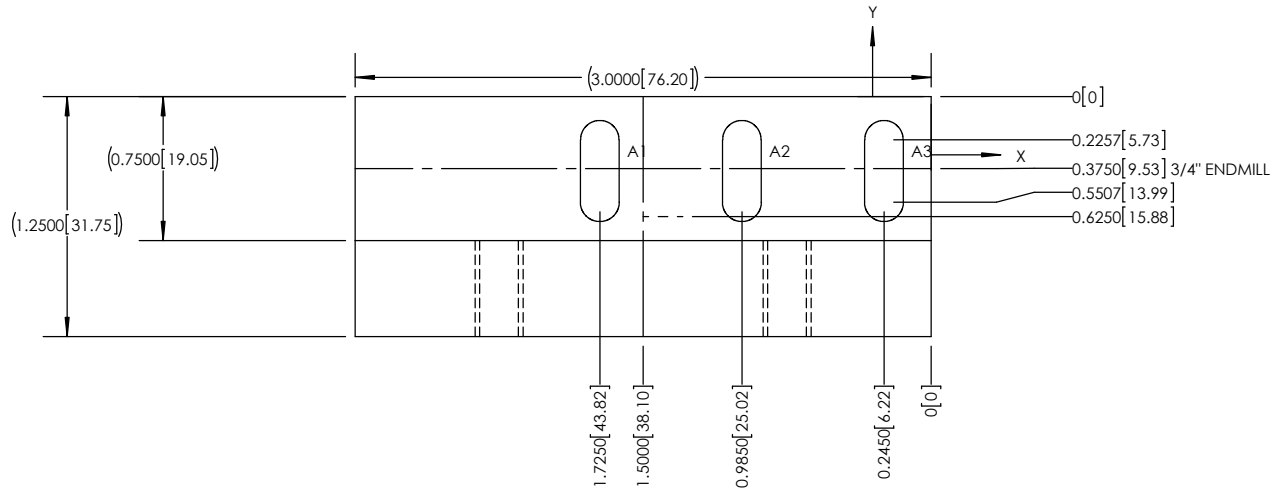

TAG	X LOC	Y LOC	SIZE
A1	-1.7250	-0.5507	.2013 X .5263
A2	-0.9850	-0.5507	.2013 X .5263
A3	-0.2450	-0.5507	.2013 X .5263

TITLE: DWG. NO. cs1000-mnt-FAB		
SIZE A	MATERIAL FINISH	REV
SCALE: 1:1	WEIGHT: 0.1361	SHEET 3 OF 4

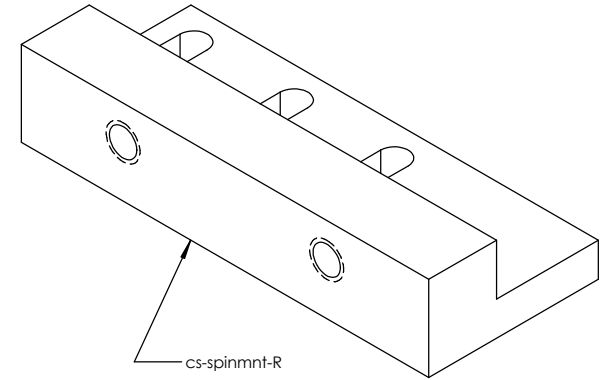
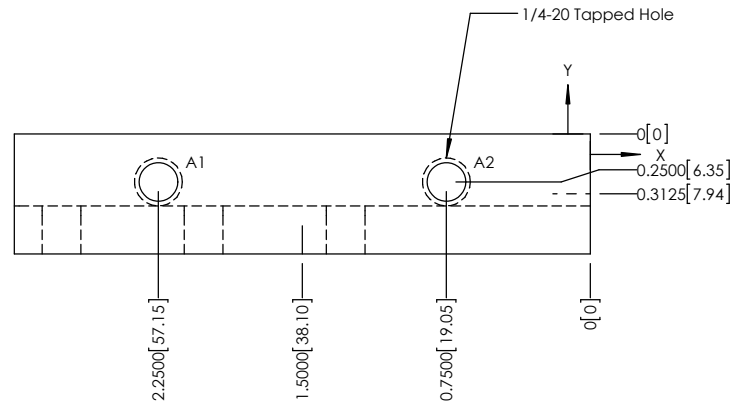
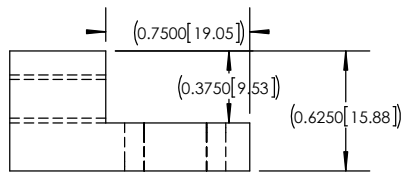

TAG	X LOC	Y LOC	SIZE
A1	-2.2500	-0.2500	Ø .2010 THRU ALL 1/4-20 UNC THRU ALL
A2	-0.7500	-0.2500	Ø .2010 THRU ALL 1/4-20 UNC THRU ALL

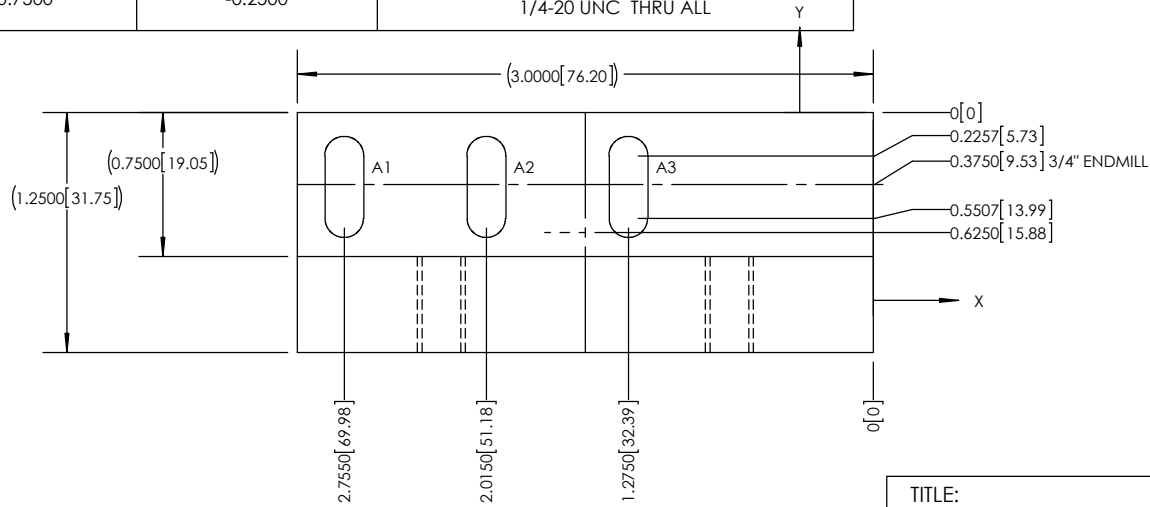

TAG	X LOC	Y LOC	SIZE
A1	-2.7550	-0.2257	.2013 X .5263
A2	-2.0150	-0.2257	.2013 X .5263
A3	-1.2750	-0.2257	.2013 X .5263

TITLE: DWG. NO. cs1000-mnt-FAB		
SIZE A	MATERIAL FINISH	REV
SCALE: 1:1	WEIGHT: 0.1361	SHEET 4 OF 4

5

↑

4

3

2

1